

**MODEL BRIDGE, FLOATING BRIDGE,
PNEUMATIC FLOAT, SUPERSTRUCTURE
(M4T6) (BOOKLET)**

GTA 05-04-034

JANUARY 1982

MODEL BRIDGE, FLOATING BRIDGE, PNEUMATIC FLOAT, SUPERSTRUCTURE(M4T6) (BOOKLET)

TABLE OF CONTENTS

	Page
INTRODUCTION	ii
Chapter 1 DESCRIPTION	1-1
Bridge Model Kit Chests	1-3
Components of Bridge Model Kit.....	1-4 through 1-9
Chapter 2 OPERATING INSTRUCTIONS	2-1
Assembly and handling Precautions	2-1
Operation Details	2-3
Erection of the Model	2-4

This GTA supersedes TM 5-267K, 28 November 1958

Chapter 3	MAINTENANCE INSTRUCTIONS	3-1
Appendix A	REFERENCES	A-1
Appendix B	HINTS TO THE INSTRUCTOR.....	B-1
Appendix C	SUGGESTED METHOD OF INSTRUCTION	C-1

The word "he" or "his" in this publication is intended to include both the masculine and feminine genders and any exception to this will be so noted.

INTRODUCTION

This GTA describes and presents instructions on the use and maintenance of the Model Bridge Training Aid, Floating Bridge, Pneumatic Float, Class 60, Aluminum Deck Balk Superstructure (M4T6). To obtain the greatest instructional value from the model bridge, refer to appendixes A, B and C.

DESCRIPTION

This bridge model kit is a 1-to-12 scale model of the Floating Bridge, Pneumatic Float, Class 60, Aluminum Deck Balk Superstructure (M4T6) and is a Department of the Army approved training aid. It is designed to be used by instructors in bridging for demonstration and practical application in classroom instruction of 30 to 40 students. The bridge model kit parts correspond closely in general appearance, function, and arrangement to the actual floating bridge. However, the bridge model kit parts are manufactured from different metals, the floats have fewer compartments, and the connections, especially the safety pins, are larger than scale. Other minor details have been simplified for ease of model fabrication and assembly.

Anchorage features of the actual bridge cannot be reproduced with the bridge model kit. The bridge model should not be used for any capacity or other physical tests. The bridge model kit can be adapted to any of the following scale model bridge assemblies:

One end of a floating bridge consisting of a 2-float reinforced end span and three normal floating bays.

A 5-float reinforced raft, complete with ramps at each end.

Deck balk, short span, fixed bridges with one trestle support, representing actual bridge lengths as listed below:

<i>38 feet 4 inches-see figure C-12a</i>	1
<i>30 feet –see figure C-12b</i>	2
<i>23 feet 4 inches-see figure C-12c</i>	1

The kit is packed in three chests as shown in figure 1-1. The chests are approximately 7 ¼ inches high by 1 foot 7 inches wide by 2 feet 5 inches long.

The components of the bridge model and the distribution throughout the chests are given in table 1. The miniature bridge components and tools contained in the chests are illustrated in figures 1-2a through 1-2d.

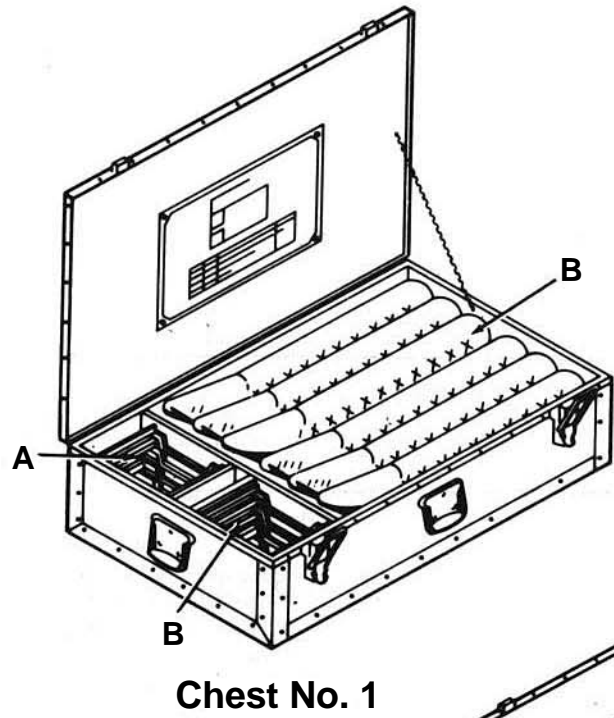

Chest No. 1

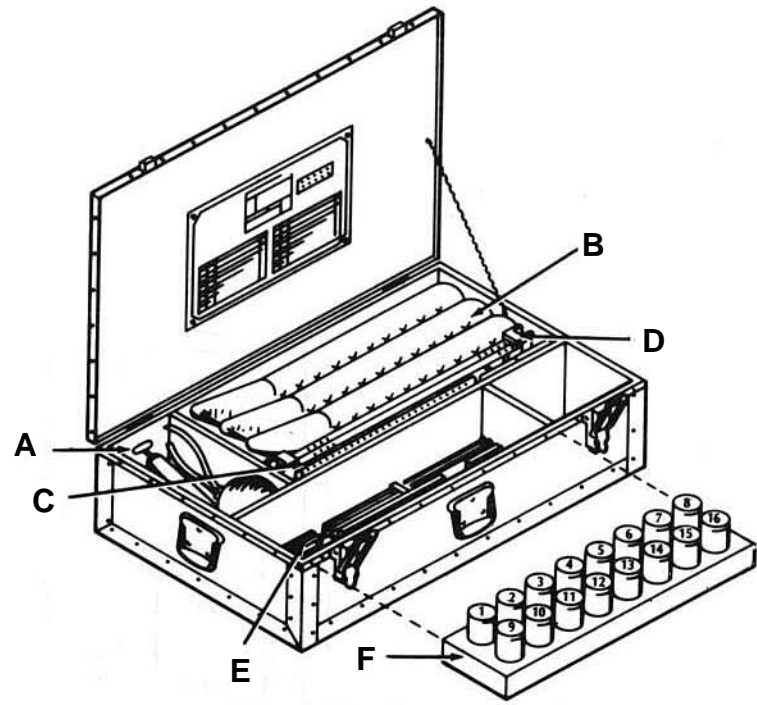

Chest No. 2

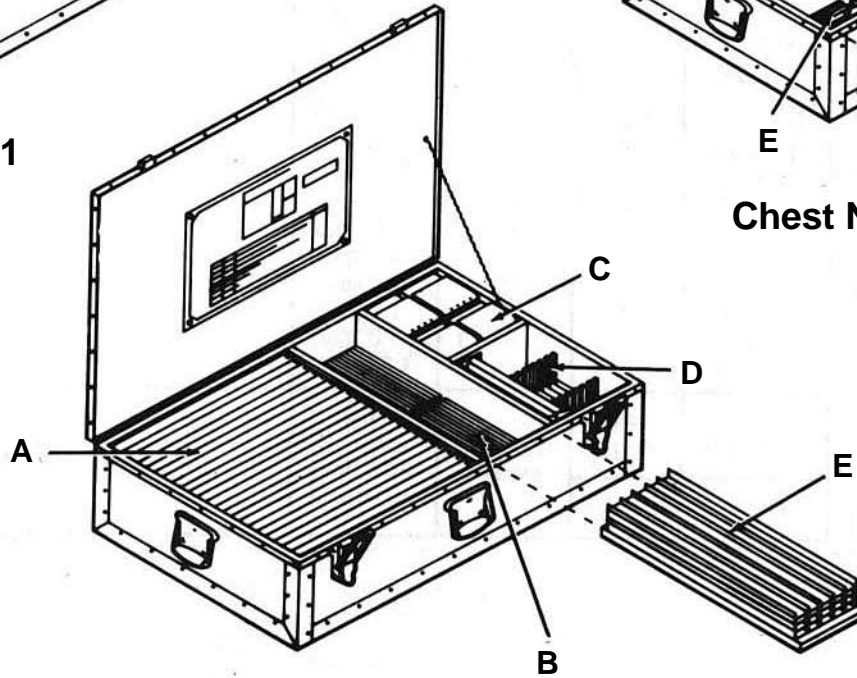

Chest No. 3

Figure 1-1. Bridge model kit chests

Table 1. Components of Bridge Model Kit
(Part 1 of 2)

Item	Corps of Engineer drawing No.	Number required	Storage in Chests	
			Chest No.	Compartment
Adapter, curb	7569-12-1	30	2	F1, 2, 3
Adapter, saddle, normal	7921-3-1	8	1	A, B
Adapter, saddle, offset.....	7921-3-2	4	1	A
Balk, deck, normal	7569-8-1	150	3	A
Balk, deck, short	7569-8-2	16	3	D
Balk, deck tapered	7569-9-1	30	3	C
Bar, connecting	7891-5-3	18	2	D
Floats, half:				
pneumatic	7891-3	4	1 & 2	IC & 2B
sponge rubber	7891-24-1	6	1 & 2	IC & 2B
Hoist, chain, ratchet				
Extractor, cotter pin	7569-29-6	1	2	A
Pin, medium length	7569-14-8	600	2	F7, 8, 9
Pin safety	7891-15-1	120	2	F10
Plate, bearing	7921-4-2	4	2	E
Plate, cover, long	7569-10-2	4	2	E
Plate, cover, short	7569-10-3	4	2	E
Pliers, needle nose.....	7569-29-7	1	2	A
Post, handrail	7569-11-1	18	2	F4, 5
Pump	7891-18-5	1	2	A

Table 1. Components of Bridge Model Kit
(Part 2 of 2)

Item	Corps of Engineer drawing No.	Number required	Storage in Chests	
			Chest No.	Compartment
Ramp pin, horizontal	7891-12-3	12	2	F6
Ramp pin, vertical	7891-12-8	20	2	F6
Ramp, raft	7569-12-2	8	3	C
Rope, handrail (ball).....	7569-11-7	1	2	A
Saddle (consisting of the following items):	7891-6	5		
Beam, center section	7891-6-1	10	3	E
Beam, end section	7891-6-2	20	3	E
Beam outrigger	7891-6-3	20	2	C
Panel, end	7891-6-2	10	3	D
Panel, interior	7891-7-1	40	3	B
Pin, saddle beam	7891-15-7	120	2	F11
Spring clip, panel	7891-15-6	300	2	F12-16
Stiffener, balk	7921-4-1	14	2	E
Trestle (consisting of the following items):	7569-3	1	2	B
Bracket, chain hoist	7569-7A	2	2	F6
Clamp, trestle bracing	7569-6	5	2	F6
Column, full	7569-3	2	2	B
Pin, screw point	7569-6-7	3	2	F6
Shoe, trestle column	7569-5-5	2	2	B
Strut, trestle bracing	7569-6-1	3	2	B
Transom	7569-3	1	2	B

Pneumatic Float

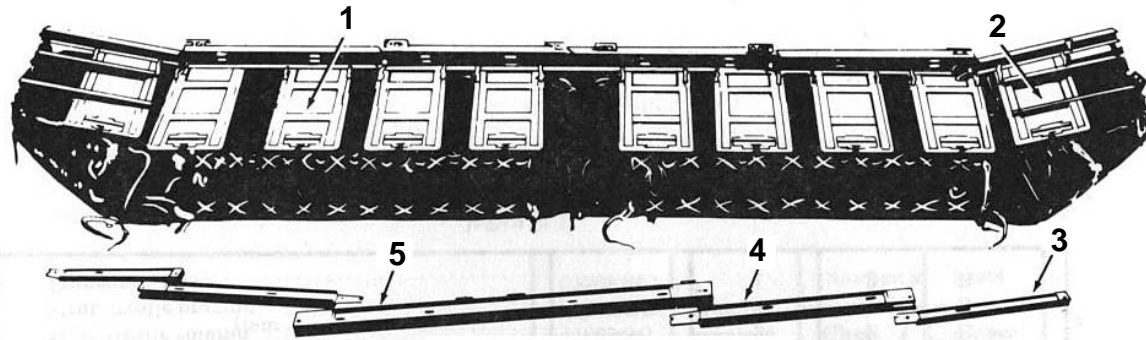

1. Interior saddle panel
2. End saddle panel
3. Outrigger beam
4. End section beam
5. Center section beam

Detail of saddle beam pin and panel spring clip in place

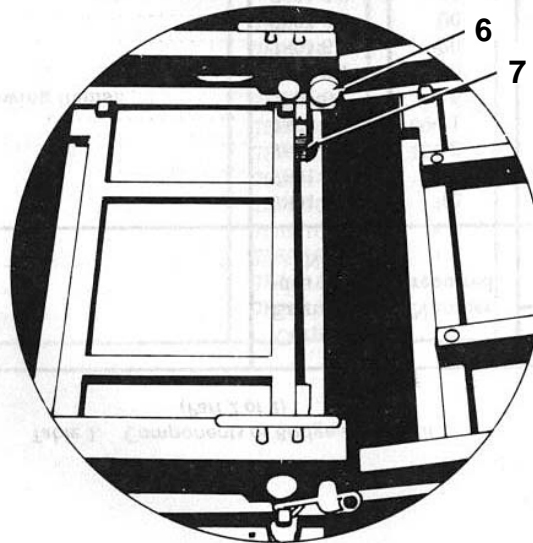

6. Saddle beam pin
7. Panel spring clip

Figure 1-2a. Float and saddle assembly components

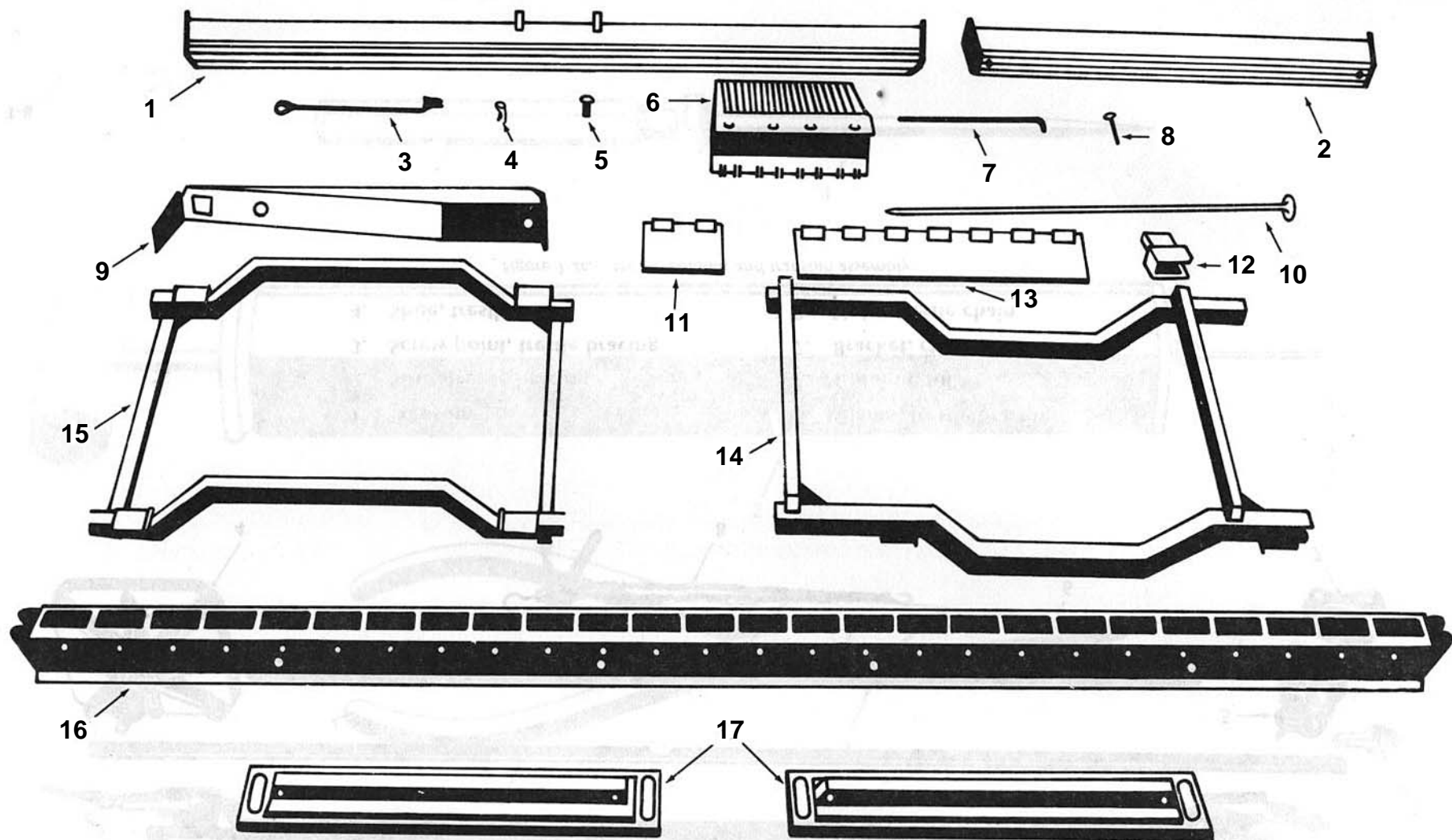

- | | | |
|------------------------|--------------------------|--------------------------------|
| 1. Balk, deck, normal | 7. Pin, ramp, horizontal | 13. Plate, cover, long |
| 2. Balk, deck, short | 8. Pin, medium, length | 14. Adapter, offset |
| 3. Post, handrail | 9. Balk, deck, tapered | 15. Adapter, normal |
| 4. Pin, safety | 10. Bar, connecting | 16. Stiffener, balk connecting |
| 5. Pin, ramp, vertical | 11. Plate, cover, short | 17. Plate, bearing |
| 6. Ramp, raft | 12. Adapter, curb | |

Figure 1-2b. Superstructure

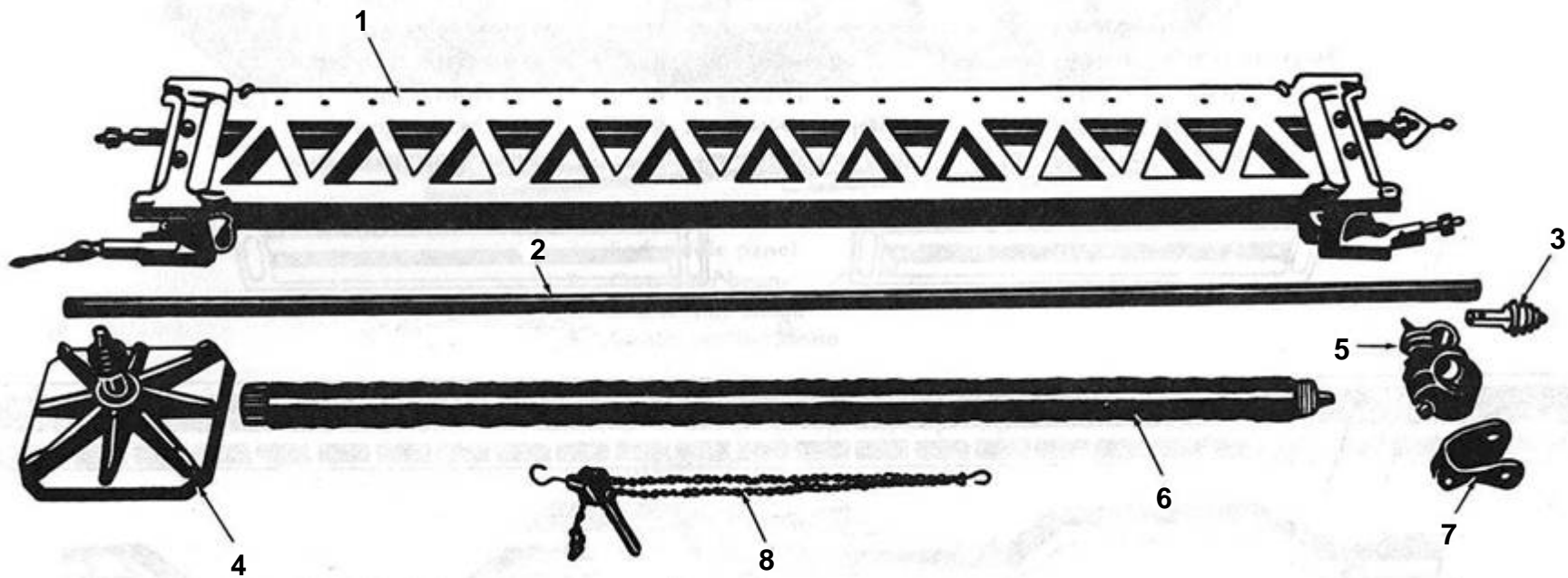

- | | |
|---------------------------------|---------------------------|
| 1. Transom | 5. Clamp, trestle bracing |
| 2. Strut, trestle bracing | 6. Column, full |
| 3. Screw point, trestle bracing | 7. Bracket, chain hoist |
| 4. Shoe, trestle | 8. Hoist, trestle chain |

Figure 1-2c. Trestle column and transom assembly

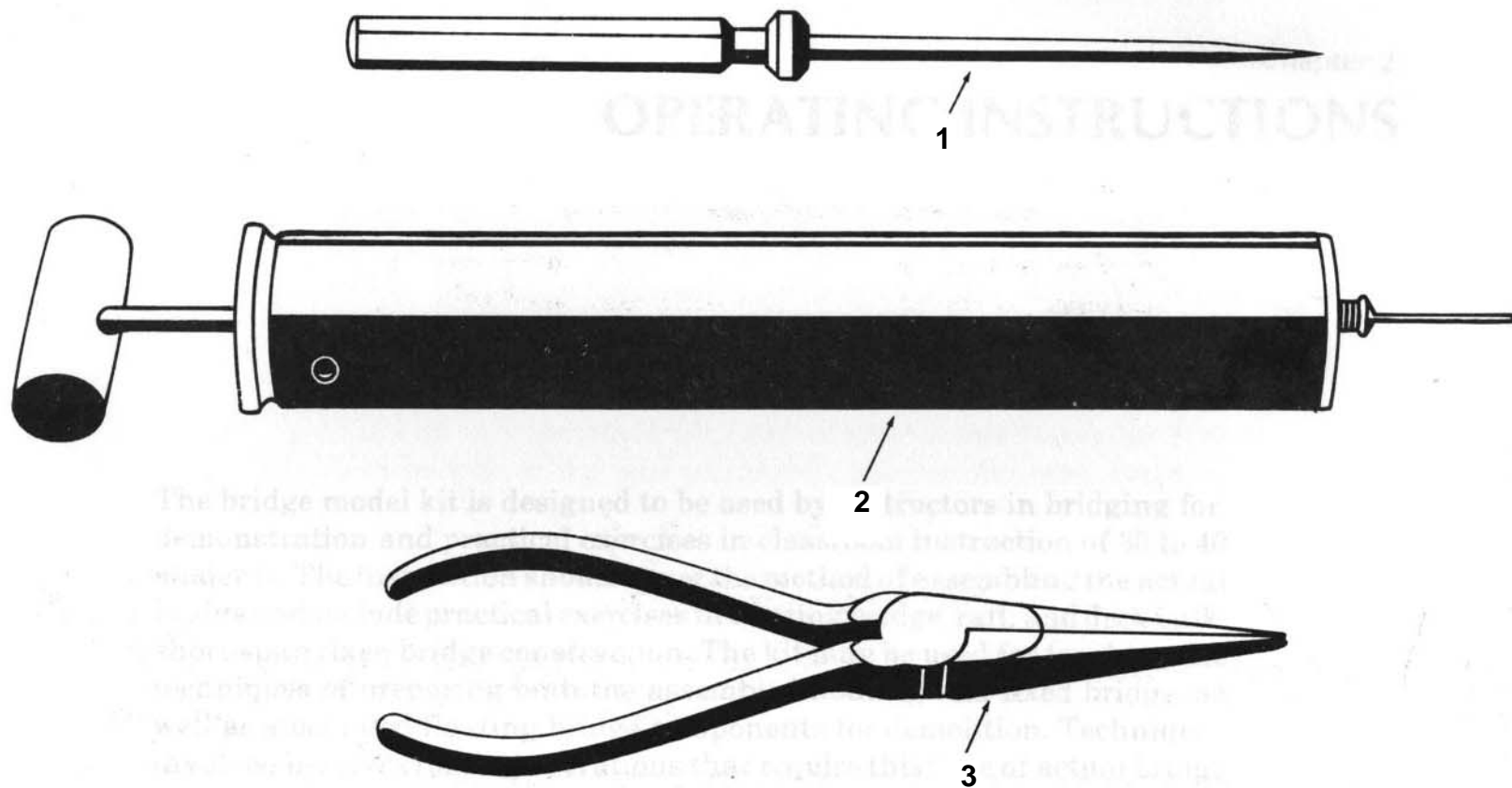

- 1. Extractor, cotter pin
- 2. Pump
- 3. Pliers, needle-nose

Figure 1-2d. Tools

OPERATING INSTRUCTIONS

The bridge model kit is designed to be used by instructors in bridging for demonstration and practical exercises in classroom instruction of 30 to 40 students. The instruction should cover the method of assembling the actual bridge and include practical exercises in floating bridge, raft, and deck balk, short-span fixed bridge construction. The kit may be used for teaching the techniques of preparing both the assembled floating and fixed bridge, as well stockpiled floating bridge components for demolition. Techniques involved in river crossing operations that require this type of actual bridge may also be demonstrated using this bridge model kit.

Assembly and Handling Precautions

Damage must be avoided in assembling and handling the bridge model kit. The following precautions must be observed:

The miniature bridge parts are manufactured of aluminum and flexible plastic. Although these parts are sturdily constructed, they may be damaged by rough handling or abuse. Handle, assemble, and disassemble the parts carefully and replace them in their proper compartments in the chests.

All fabricated parts are manufactured with appropriate tolerances for simple, easy assembly. When holes and connections are properly aligned, no force is required to insert pins or fasteners. Do NOT under any circumstances, drive pins into holes or lock fasteners by force. Pins, fasteners, other parts must NOT be used for purposes other than those for which they were designed.

Do NOT apply test loads to the bridge. Loads applied to the assembled model bridges may damage members and connectors.

Always pick up assembled sections by their supporting platform. Suspension of assembled sections causes undue stress on their component parts.

When removing and replacing parts in the trays of the chest, do so gently. Proper placement of parts in the trays, and trays in the chest, permits easy fitting of the trays and closing of the chests. Under no circumstances are the chest lids to be forced closed.

Operational Details

The Bridge Model Kit, Training Aid, Floating Bridge, Pneumatic Float, Class 60, Aluminum Deck Balk Superstructure (M4T6) is primarily to be used for instruction on the basic assembly of the floating bridge, fixed span, or raft. It may also be useful for illustrating the engineer missions in an overall operation requiring any one form of assembly of the bridge components. Appendix C describes and illustrates assemblies which may be demonstrated with this bridge kit.

In considering how to make use of the model, so that the class will obtain the greatest instructional value from it, the following factors should be kept in mind:

Specific subject matter of the lecture.

Number of students.

Working space available.

Time allotted.

Number of participating instructors.

Available training films and film strips.

Reference materials.

The instructor should carefully organize the period of instruction, using the hints in appendix B and adopting a procedure of instruction similar to that outlined in appendix C. Realistic simulated bridge sites, proper division of students into working groups, and facilities for group work stations will do much to insure the success of the instruction. This requires careful preplanning. TM 5-210 (Military Floating Bridge Equipment) will be a

valuable guide for the class in adapting the model erection procedures to the actual full-size Floating Bridge, Pneumatic Float, Class 60, Aluminum Deck Balk Superstructure (M4T6) equipment. The instructors must be entirely familiar with TM 5-210 to enable them to compare each component of the model to the corresponding full-scale bridge component.

Erection of the Model

The instructor must adapt the model kit to best illustrate a given course of instruction. In general, the step-by-step procedures should be the same as those used in assembly of the actual bridge. The instructor will use the following outline as a guide to his presentation:

PREPARATORY INFORMATION

- **Site and approach problems.**
- **Factors affecting type, method, and direction of assembly.**
- **Anchorage methods.**
- **Types of approaches and development of shore connections.**
- **Type of span suited to specific conditions.**
- **Employment of rafts.**
- **Special conditions to be considered such as tides and stream velocity.**
- **Appropriate use of film, film strips, and references.**
- **Demolition measures.**

ERECTION PROCEDURES

- **Description of model to be assembled for a specific lecture.**
- **Direct comparison to actual bridge.**
- **Description of individual parts and their nomenclature.**
- **Pertinent review of TM 5-210.**
- **Standard methods of assembly.**
- **Expedient methods of assembly.**
- **Where the model fails to incorporate all steps pertinent to actual assembly, the instructor should fill the gaps with lecture material.**

TOOLS AND EQUIPMENT

- **Description and explanation of use of tools, pins, and fasteners.**
- **Discussion on care of tools and parts.**
- **Indication of differences between model and actual bridge, to include:**
 - Simulated bolts and spring clips.**
 - Lugs and built-up section for simulating plates.**
- **Emphasis on repacking instructions.**

SETUP FOR WORK TABLES AND CLASSROOM

- **Preparations for setting up the model.**
- **Division of class into work groups with responsible instructors.**
- **Designation of work group stations.**

MAINTENANCE INSTRUCTIONS

Maintenance Instructions for Agency Assigned Kit

Chests must be stored in a cool, dry place away from radiators or other heating devices. Interior and exterior of chests and individual parts must be painted and kept in good repair. Maintain a continuous check of chest contents. See figure 1-1 and table 1 for proper placement in the chests. Issue necessary instructions to prevent rough handling of chests and component parts.

Maintenance Instructions for Personnel Using Kit

Chests must be stored in a cool, dry place away from radiators or other heating devices. At all times, handle chests and components with care, and keep components clean.

After use, see that all items are replaced in proper compartments as shown on the charts inside the lid of each chest.

Report any lost, damaged, or destroyed parts to the agency to where the model is assigned.

Replacement and Repair

Replacement parts may be obtained through local TASCs.

REFERENCES

1. TECHNICAL MANUALS (TM)

TM 5-210 **Military Floating Bridge Equipment**

2. FIELD MANUALS (FM)

FM 5-34 **Engineer Field Data**

FM 21-6 **How to Prepare & Conduct Military Training**

FM 21-30 **Military Symbols**

FM 90-13 **River Crossing Operations**

3. ARMY REGULATIONS (AR)

AR 310-25 **Dictionary of United States Army Terms**

AR 310-50 **Authorized Abbreviations and Brevity Codes**

4. DEPARTMENT OF THE ARMY PAMPHLETS (DA Pam)

DA Pam 108-1	Index of Army Motion Pictures, and Related Audio-Visual Aids
DA Pam 310-Series	Index of Administrative Publications
DA Pam 310-12	Index and Description of Army Training Devices

5. TRAINING FILMS

TF 5-2683	The M4T6 Floating Bridge
------------------	---------------------------------

6. TRAINING EXTENSION COURSES (TEC)

Bridging Anchoring Systems

030-051-6482-F	Introduction
030-051-6483-F	Emplaced Deadman
030-051-6484-F	Shore Guys
030-051-6485-F	Approach Guys
030-051-6486-F	Kedge and Combination
030-051-6487-F	Overhead Positioning
030-051-6488-F	Overhead Tower Erection
030-051-6489-F	Overhead Cable Attachment
030-051-6490-F	Overhead Near Shore Lines
030-051-6491-A	Determine Float Bridge Overhead Anchorage Systems Requirements, Part I
030-051-6492-A	Determine Float Bridge Overhead Anchorage Systems Requirements, Part II
030-051-6493-A	Determine Float Bridge Overhead Anchorage Systems Requirements, Part III

Diesel Bridge Erection Boats

- | | |
|-----------------------|--|
| 030-051-6425-J | Perform Operator Maintenance on Bridge Erection Boats |
| 030-051-6426-F | Launch the 27-ft Diesel Bridge Erection Boat |
| 030-051-6427-F | Retrieve the 27-ft Diesel Bridge Erection Boat |
| 030-051-6428-F | Operate the 27-ft Diesel Bridge Erection Boat |

Universal Trestle Assembly M4T6 Fixed Span

- | | |
|-----------------------|-----------------------------------|
| 030-051-6301-F | Universal Trestle Assembly |
| 030-051-6302-F | Position Adjustment |
| 030-051-6303-F | 2nd Trestle, Class 100 |
| 030-051-6304-F | Fixed Span, Part I |
| 030-051-6305-F | Fixed Span, Part II |

Float Bridge/Raft M4T6 Assembly

- | | |
|------------------------|---|
| 030-051-6322-F | Introduction |
| 030-051-6323-F | Site Layout and Float Inflation |
| 030-051-6324-F | Construct Saddle Assembly, Part I |
| 030-051-6325-F | Construct Saddle Assembly, Part II |
| 030-051-6326-FF | Launch Floats |

HINTS TO THE INSTRUCTOR

Simulated Bridge Sites and Methods

Classroom techniques should include prepared models of banks, streams, and gorges in order to realistically present instruction with the Class 60 (M4T6) Model Bridge Kit. Such terrain models should correspond in scale to the bridge model. One inch on the bridge model is equivalent to 12 inches on the bridge.

Table sizes for models other than those presented in appendix C may be computed easily by using the model scale of 1 to 12 for any given assembly.

Realistic abutment support may be made by using blocks of plywood of suitable sizes.

Miniature cranes, trucks, and other machinery and equipment may be used for illustrating assembly layouts and operations. This equipment is not available through Army supply channels.

River Crossings

Techniques may be devised using this model bridge kit to demonstrate river crossing operations in direct connection with specific combat problems, for advanced training of combat engineers, and groups of individuals of other arms and services.

Demolition

The model bridge kit is also useful in demolition training. Simulated scaled charges may be used to demonstrate actual field methods of destruction of floating bridges.

SUGGESTED METHOD OF INSTRUCTION

Guidelines

The level of classroom instruction using this floating bridge model, training aid kit must vary somewhat to fit the bridging experience and training level of each specific group. For students familiar with floating bridge equipment in general, and with the techniques of rafting, anchoring, and guying, which are common to all types of bridging, introductory lectures may be brief with emphasis placed on the practical aspects of assembling the bridge. For students not familiar with floating bridge equipment and its uses, the practical work should be preceded by a thorough introduction to include general considerations for use of the equipment, parts nomenclature, capacities, traffic control, site preparation and supplies, anchorages, and preparation for assembly. In any event, these topics should be presented for assembly preparation.

It is advisable to provide 4 periods totaling 7 hours for the presentation. The first 2 hours are a conference period to explain the use, capabilities, nomenclature, and assembly of the bridge. This introductory period includes elementary subject matter for uninitiated personnel. For more advanced students, special uses and more complex problems are substituted for the basic material. The second 2-hour period is a practical exercise in the assembly of a 5-Float Floating Bridge. The third 2-hour period is a practical exercise in the construction of a 5-Float Raft. The fourth 1-hour period is a practical exercise in the assembly of short-span fixed bridges. During the practical exercises, when the method of the model assembly differs from that of the actual bridge, the instructor should cover the actual bridge assembly method visually with photographs, drawings or other suitable training aids.

For practical exercises in periods 2 through 4, organize the class into groups similar to size and organization of the erection parties for the type of construction to be practiced, as described in TM 5-2 10. During the practical exercises, the tools issued with the model kit should be centrally located and available for use by all groups.

First Period

Introduction, Nomenclature, Organization, and Layout.

Divide this 2-hour period into 4 parts of 30 minutes duration.

Classroom Procedure

Part 1. Describe the characteristics of the bridge, its capabilities and limitations. Discuss access routes, approaches, choice of site, types of spans to be used, bridge capacities under various conditions of stream velocity, traffic control, and maintenance procedures.

Part 2. Describe the bridge model components, comparing them to the full-size bridge. Emphasize part and section nomenclature, using figures 1-2a through 1-2c, and table 1 for illustration purposes.

Part 3. Discuss layout of the site for supply and assembly purposes, personnel and equipment requirements, shore connections (ramps and trestle to fit near- and far-shore conditions), methods of anchoring, the types, methods and directions of assembly, and factors which affect the selections of each, see TM 5-210.

Part 4. Divide the class into three groups. The instructors should point out to each group, in rotation, the working space to be used, the type of bridge to be assembled, and the general organization of the class for each of the following three periods. A summary and critique of the material covered in this entire period should be conducted in the time remaining.

Classroom Setup

On a table the instructor lays out in logical order, a sample of each component of the bridge kit (table 1). These samples will be used to demonstrate the use and nomenclature of each part. He assembles typical sections, or provides suitable training aids (drawings or photographs) to illustrate their nomenclature and use. Also, the instructor provides typical scaled mock-ups and illustrations to assist in demonstrating siting, shore connections, approaches, and anchorage. Typical sections, or photographs should be used to illustrate the practical work which the students will do in the following periods.

Text References

FM 90-13 (River Crossing Operations) contains information on reconnaissance for crossing sites; TM 5-210 (Military Floating Bridge Equipment) contains information on abutment preparation and anchorage, personnel requirements, assembly area layouts, and detailed procedures for the assembly of the bridge components.

Second Period

Assembly of 5-Float, Floating Bridge and Trestle

Classroom Procedure

First Hour

Groups 1 and 2. Assign groups 1 and 2 to the work stations containing the components (table C-1) required for 2 pneumatic floats, figure 1-2a, and have each group inflate and assemble 1 complete float with saddle assembly (figs. C-1 through C-8). One float assembly will use the normal saddle adapter (fig. C-5), and the other float will use the offset saddle adapter (fig. C-7). The actual pneumatic half floats are normally stored, issued, transported, and used as a single float assembly. The model float should be treated likewise. Disassembly (unlacing) and reassembly (lacing) are done only for the purpose of maintenance and repair. The float should be laid out assembled; students should unlace it (partially, if time is limited) and replace it, prior to inflation and placement of saddle assemblies.

Group 3. Assign group to the work station containing the components (table C-2) required for the assembly of three sponge rubber floats, and have the group assemble the three floats complete with saddle assemblies using normal saddle adapters (fig. C-5).

Second Hour

For the second hour, divide groups 1, 2, and 3 into 2 groups, namely 4 and 5.

Group 4. Assign group 4 to the work station containing the components (Continued page C-14)

Table C-1. Components Required for Assembly of Two Pneumatic Floats, One Float Utilizing a Normal Saddle Adapter and One an Offset Saddle Adapter

Item	Number required
Adapter, saddle, normal	2
Adapter, saddle, offset.....	2
Bar, connecting	6
Float, half, pneumatic	4
Saddle (consisting of the following items):	2
Beam, center section	4
Beam, end section	8
Beam, outrigger	8
Panel, end	4
Panel, interior	16
Pin, saddle beam	16
Pin, safety	22

Table C-2. Components Required for Assembly of Three Sponge Rubber Floats Utilizing Normal Saddle Adapters

Item	Number required
Adapter, saddle, normal	6
Bar, connecting	9
Float, half, sponge rubber	6
Saddle (consisting of the following items):	3
Beam, center section.....	6
Beam, end section.....	12
Beam, outrigger	12
Panel, end	6
Panel, interior	24
Pin, saddle beam	24
Pin, safety	33

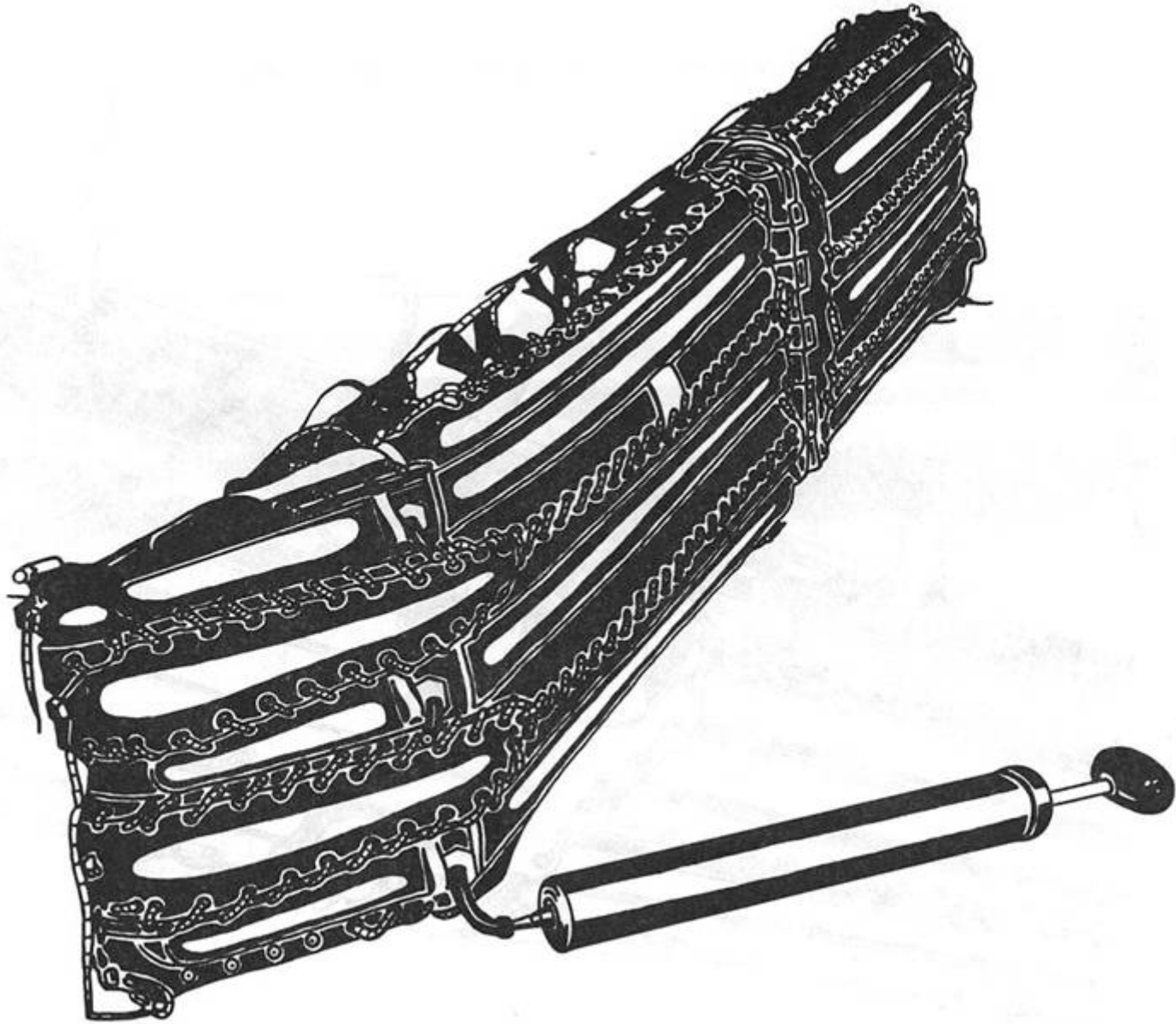

C-7

Figure C-1. Float inflation

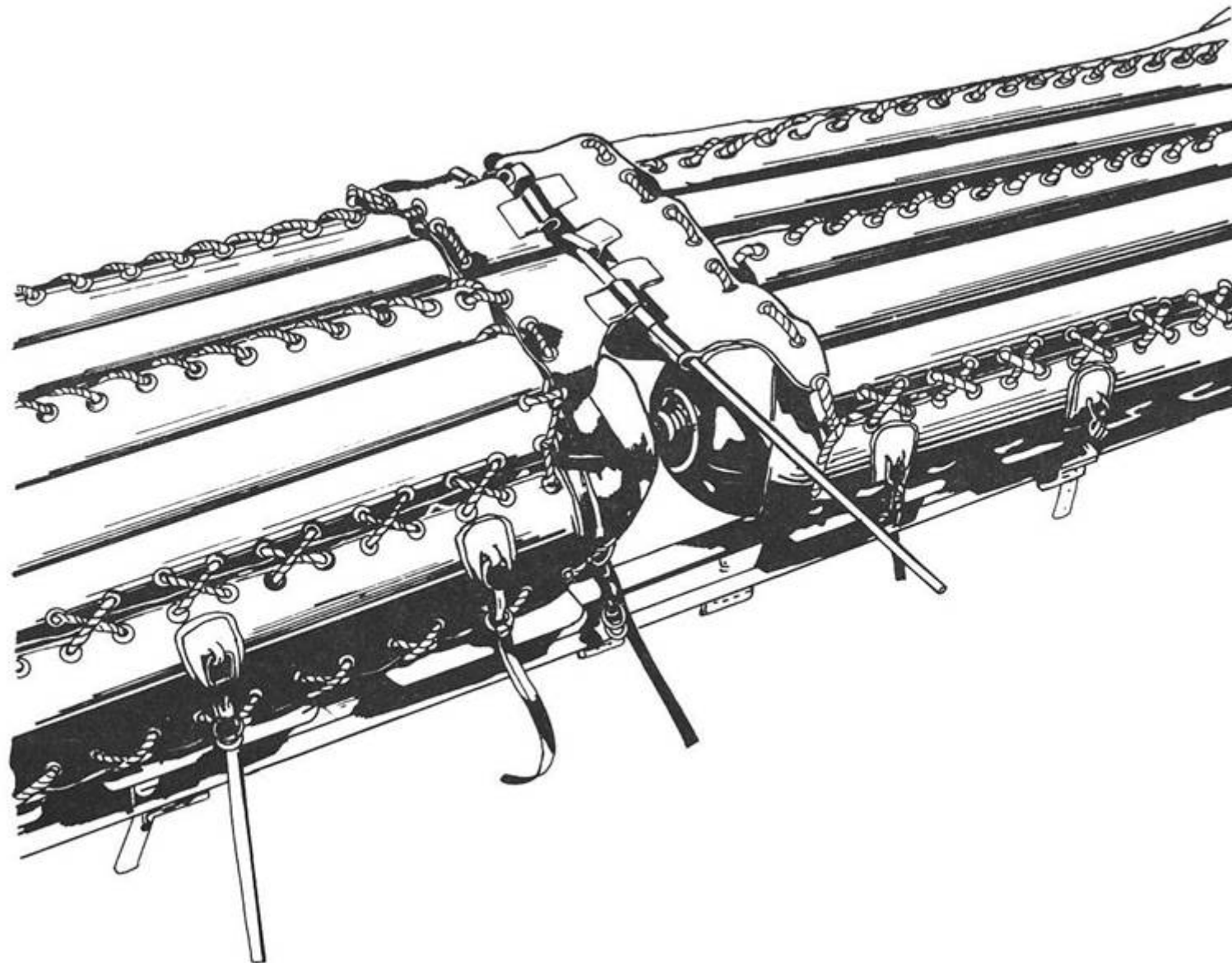

C-8

Figure C-2. Stern skirt showing method of connecting half floats

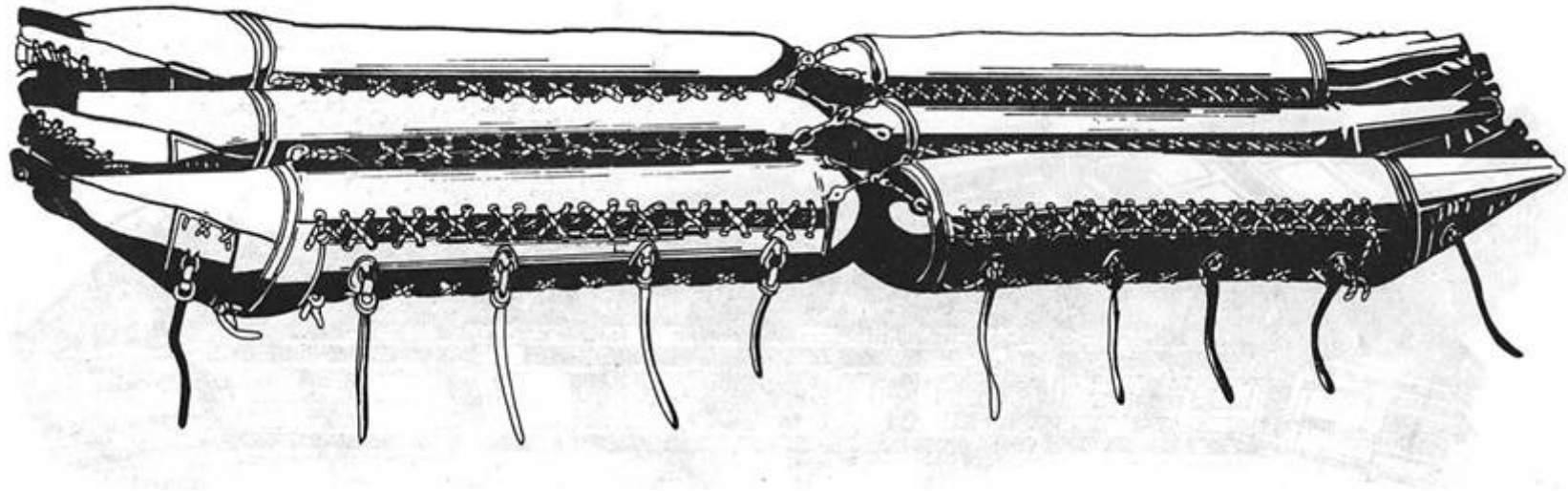

Figure C-3. Complete float ready for saddle assembly

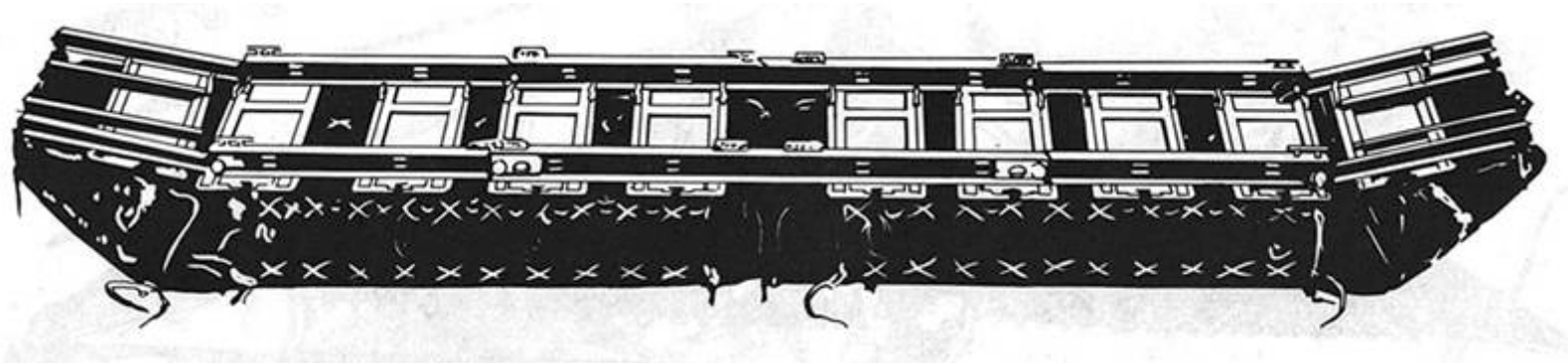

Figure C-4. Float with saddle assembly in place

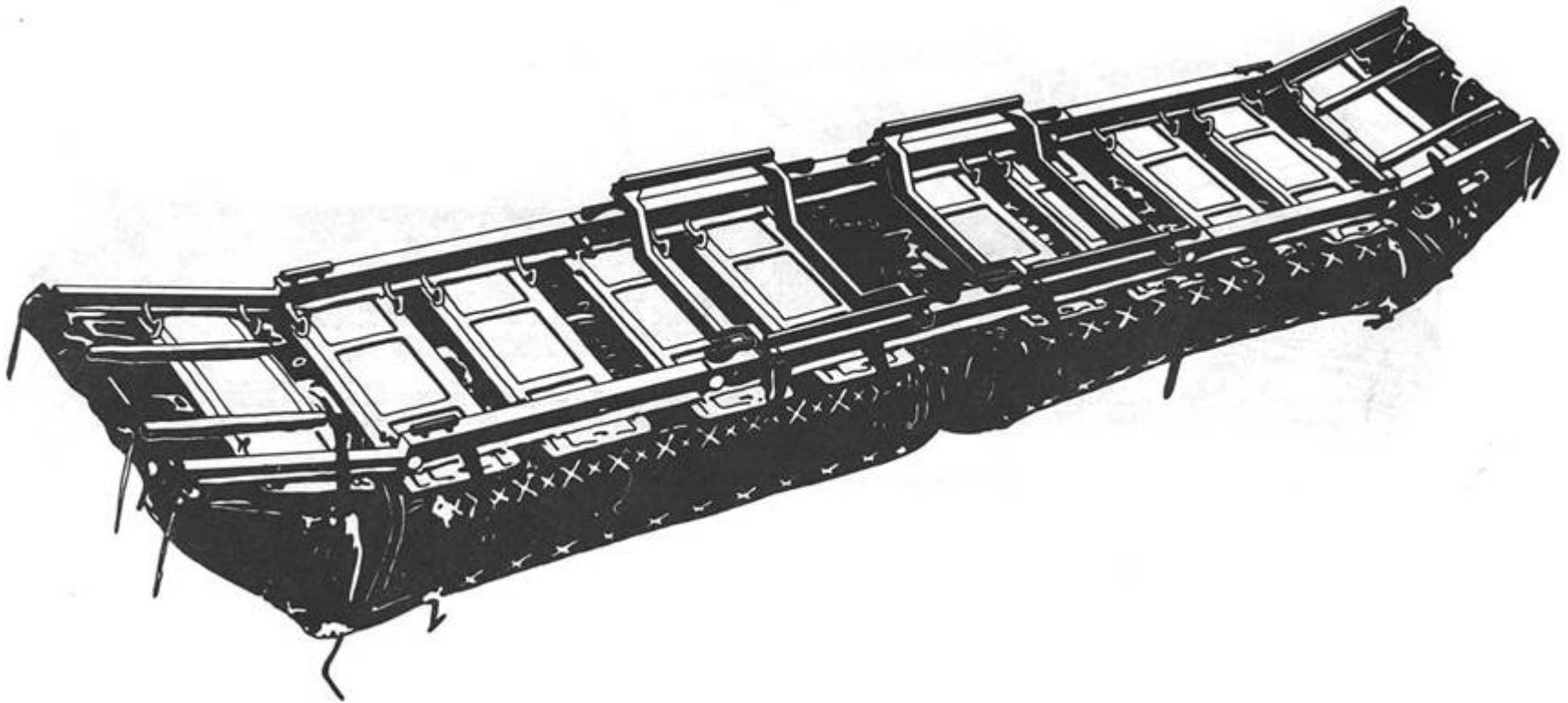

Figure C-5. Normal saddle adapters in place

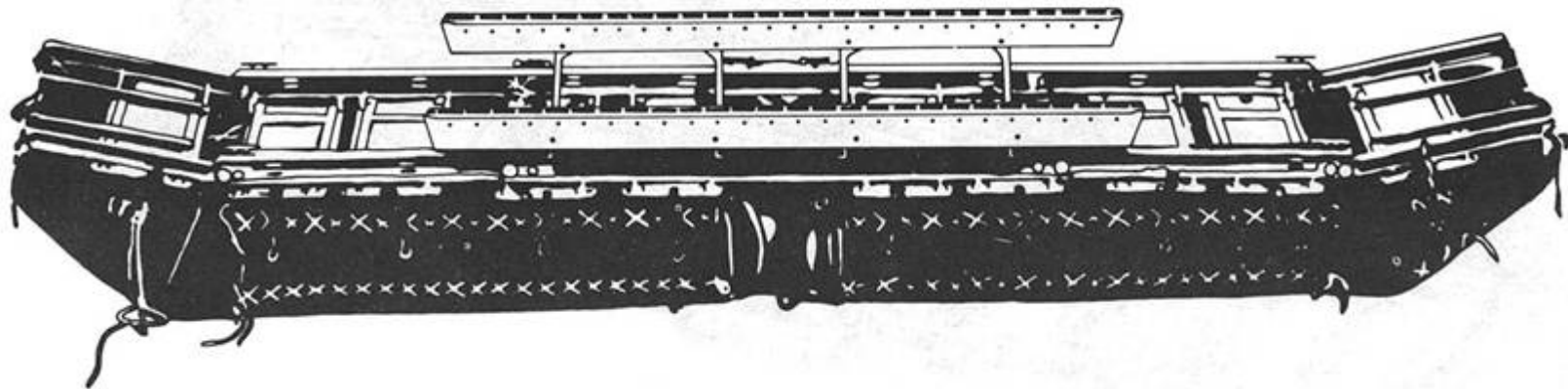

Figure C-6. Balk stiffener in place on normal saddle adapters

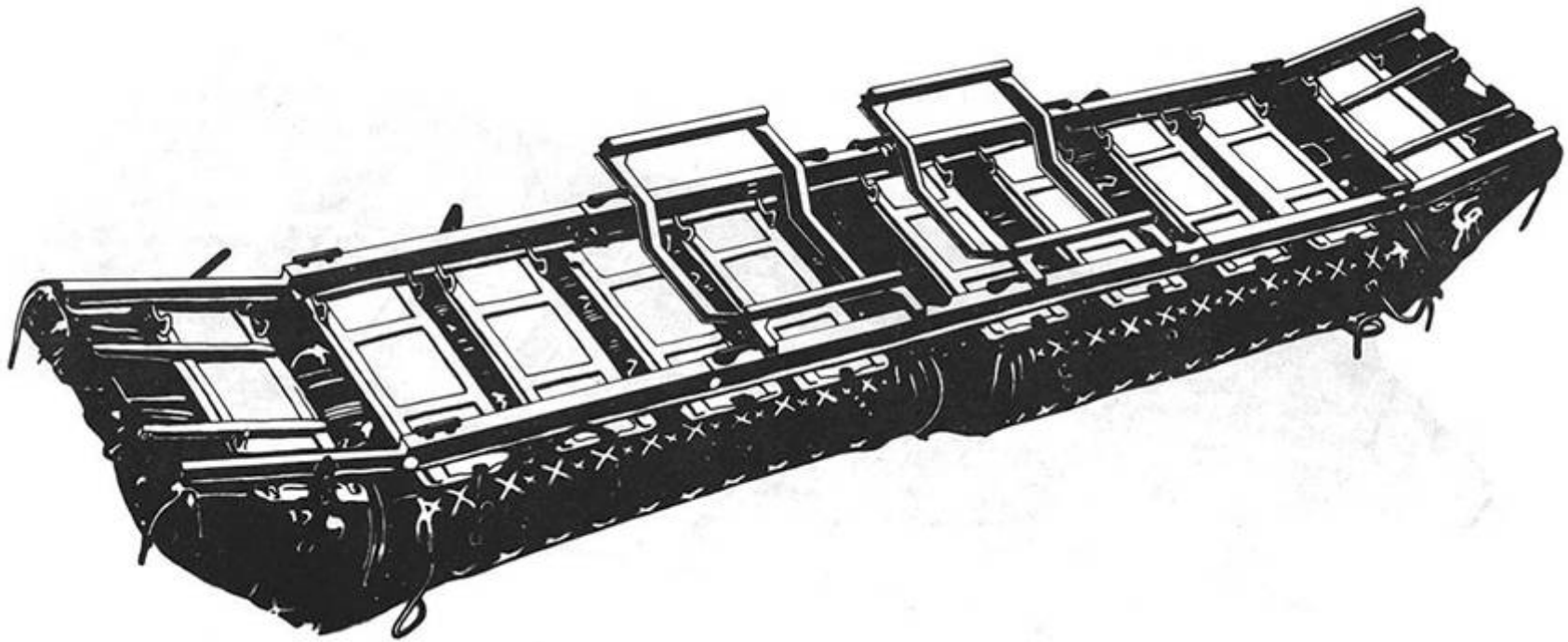

Figure C-7. Offset saddle adapters in place

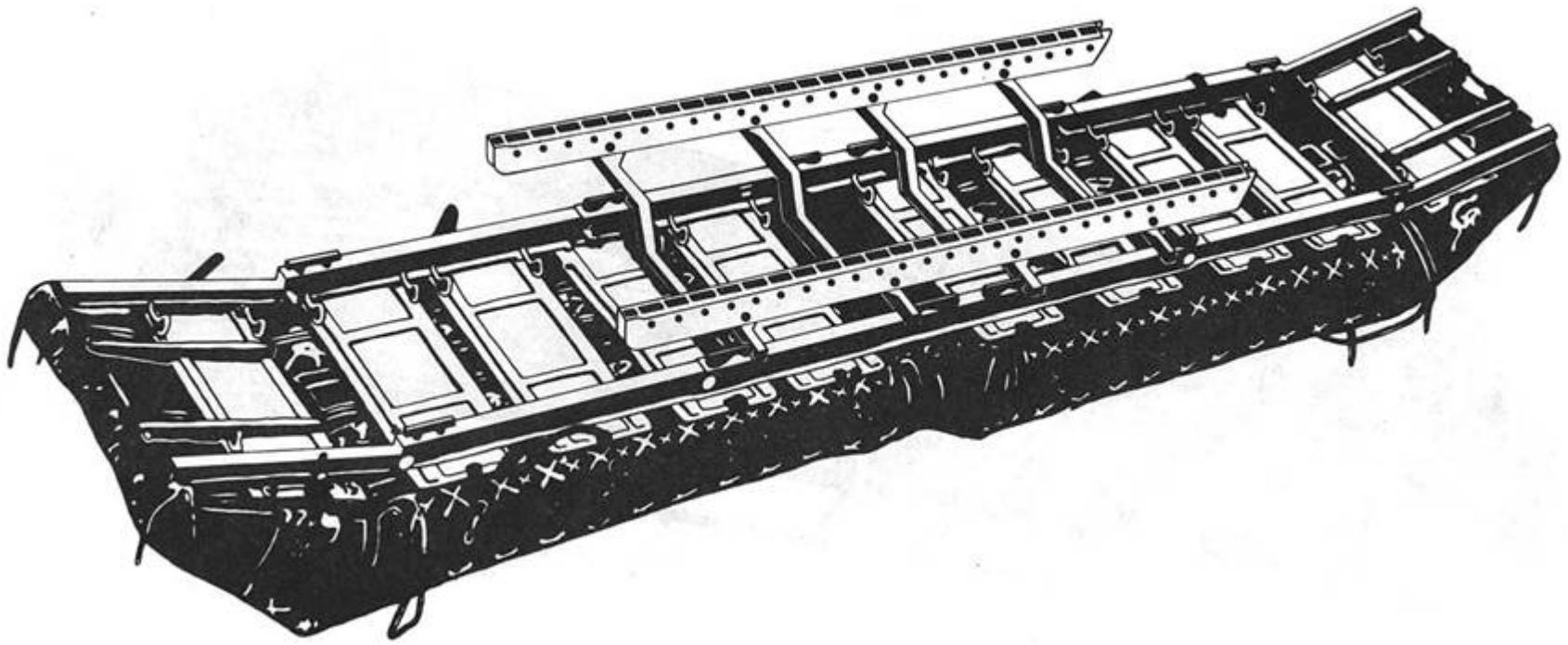

Figure C-8. Balk stiffener in place on offset saddle adapters

required to construct the superstructure for the 5-Float, Floating Bridge, on previously assembled floats and saddles, as shown in table C-3 and figure 1-2b. Have them construct the superstructure as shown in figures C-9 and C-10.

Group 5. Assign group 5 to the work station containing the components required to construct a trestle as shown in table C-4 and figure 1-2c. Have them assemble a trestle consisting of two columns and a transom.

Group rotation. When each group has completed its work, rotate the groups so that each gets experience in superstructure and trestle construction.

Instruction. During both parts of the period, the instructors at each work station observe and correct the work of the students, emphasizing the use of correct nomenclature for the bridge parts and proper methods of assembly.

Classroom Setup

For the second period, the instructor provides the necessary simulated bridge sites and arranges the student work stations as follows:

First Hour

Work stations for groups 1 and 2. Provide a table surface for each station large enough to accommodate one pneumatic float with saddle assembly. Provide a removable platform (1 ft x 4 ft) on which to assemble the model sections. Have available the components shown in table C-1 and figures 1-2a and 1-2b.

**Table C-3. Components Required to Construct Superstructure
(Deck Balk and One End Ramp) for Bridge with Reinforced End
Section**

Item	Number required
Adapter, curb	26
Balk, deck, normal	131
Balk, deck, tapered	29
Pin, (medium length)	102
Plate, cover, long	4
Plate, cover, short	4
Plate, bearing	2
Post, handrail	13
Rope, handrail (ball)	1
Spring, clip, panel	200
Stiffener, balk	13

Table C-4. Components Required to Assemble a Trestle

Item	Number required
Hoist, chain, ratchet	2
Trestle assembly (consisting of the following items):	1
Bracket, chain hoist	2
Clamp, trestle bracing	2*
Column, full	2
Pin, screw point	2
Shoe, trestle column	2
Strut, trestle bracing	2*
Transom	1

*3 additional clamps trestle bracing and 1 additional strut are provided as spares.

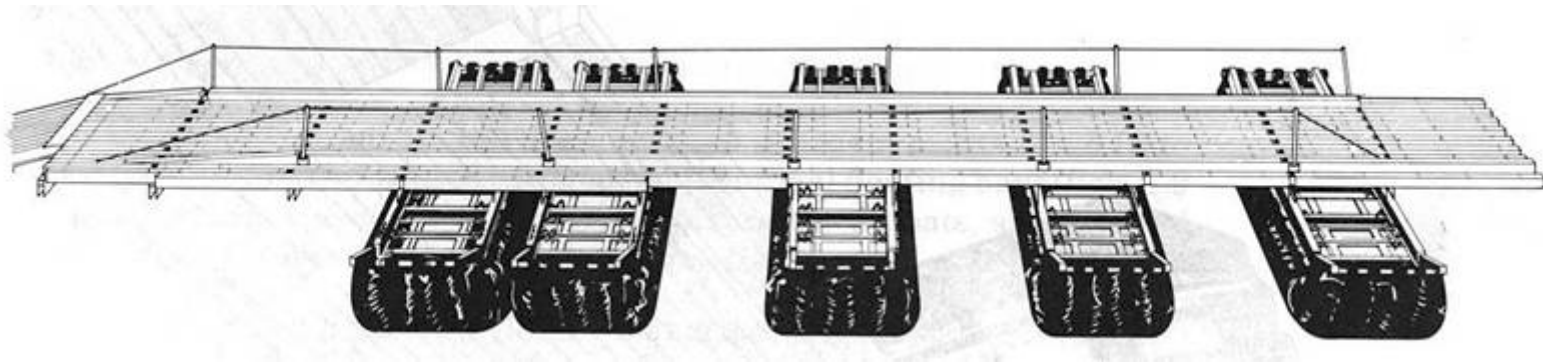

Figure C-9. Completely assembled floats and superstructure for one end of a floating bridge consisting of a 2-float reinforced end span with ramp and three normal floating bays.

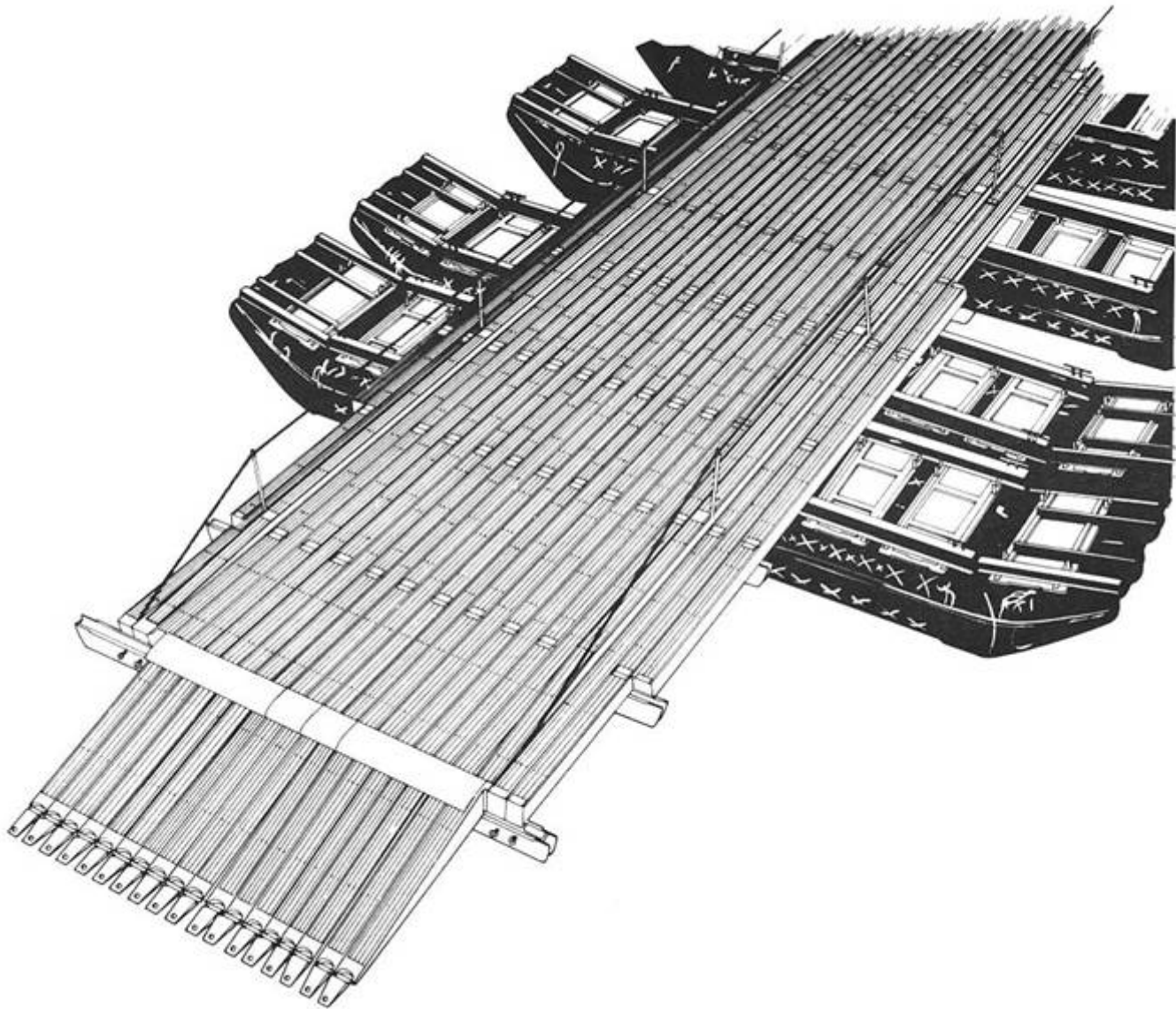

Figure C-10. Close-up of assembled ramp and superstructure

Work station for group 3. Provide a table surface large enough to accommodate three floating bays properly spaced for the assembly of a floating bridge section (fig. C-9). Provide a removable plywood platform (4 ft x 5 ft) on which to assemble the model section, so that it may be moved during the second part of the period for assembly with floating bays assembled at work stations 1 and 2. Make available the components shown in table C-2 and figures 1-2a and 1-2b.

Second Hour

Work station for group 4. Provide a table of sufficient size (4 ft x 8 ft) to assemble a 2-float reinforced end span and 3 normal floating bays (figs. C-9 and C-10). Have available the previously assembled floats, saddles, and components shown in table C-3 and figure 1-2b.

Work station for group 5. Provide a table surface of sufficient size (4 ft x 4 ft) to accommodate the assembly of a trestle with adequate space for parts and tools used during assembly. Have available the trestle components listed in table C-4 and figure 1-2c.

Instructors Notes

During the progress of the work, maintain a time check on the progress of each group to assure that completion will be uniform. For the benefit of all students, describe and explain the problems that arise during the work of any one group. When final assembly of all components is completed, insure by summary and critique that all students are familiar with nomenclature and assembly procedure for all parts of the bridge.

Text References

TM 5-210 (Military Floating Bridge Equipment) and FM 5-34 (Engineer Field Data).

Disassembly

Have the students disassemble the model and replace the components in the chests.

Third Period

Assembly of 5-Float Reinforced Raft with Ramps at Each End.

Classroom Procedure

First Hour

Groups 1 and 2. Assign groups 1 and 2 to the work station containing the components (table C-2, replace two normal saddle adapters with two offset) required for assembly of three sponge rubber floats. Have the groups assemble the three floats, complete with saddle assemblies. Two float assemblies will use the normal and one will use the offset saddle adapters.

Group 3. Assign group 3 to the work stations containing the components (table C-1 and figs. 1-2a and 1-2b) required for two pneumatic floats. Have the group inflate and assemble 1 float with saddle assembly (figs. C-1 through C-8). One float will use the normal saddle adapter (fig. C-5), the other float will use the offset saddle adapter (fig. C-7).

Second Hour

For the second hour divide groups 1, 2, and 3 into two groups, namely 4 and 5.

Groups 4 and 5. Assign groups 4 and 5 to the work station containing the components (table C-5) to construct the raft superstructure (lay deck balk and raft ramps) on the previously assembled floats and saddles. Complete the raft assembly as outlined in TM 5-210. Insure that the floats with the offset saddle adapters are properly positioned (fig. C-11).

Group 4 constructs the superstructure, while group 5 observes. Upon completing its work, group 4 observes, while group 5 constructs the superstructure. Conclude the period with a summary and a critique of the problems covered in this period.

Instruction. During both parts of the period, the instructors at each work station observe and correct the work of the students, emphasizing the use of correct nomenclature for the raft parts and proper methods of assembly.

Classroom Setup

**For the third period the instructor provides the necessary simulated rafting sites and arranges the student work stations as follows:
(Continued page C-25)**

**Table C-3. Components Required to Construct Superstructure
(Lay Deck Balk and Raft Ramps) on 5-Float Reinforced Raft with Ramps**

Item	Number required
Adapter, curb	20
Balk, deck, normal	112
Balk, deck, short	16
Pin, medium length	118
Ramp pin, horizontal	8
Ramp pin, vertical	16
Ramp, raft	8
Stiffener, balk connecting	14

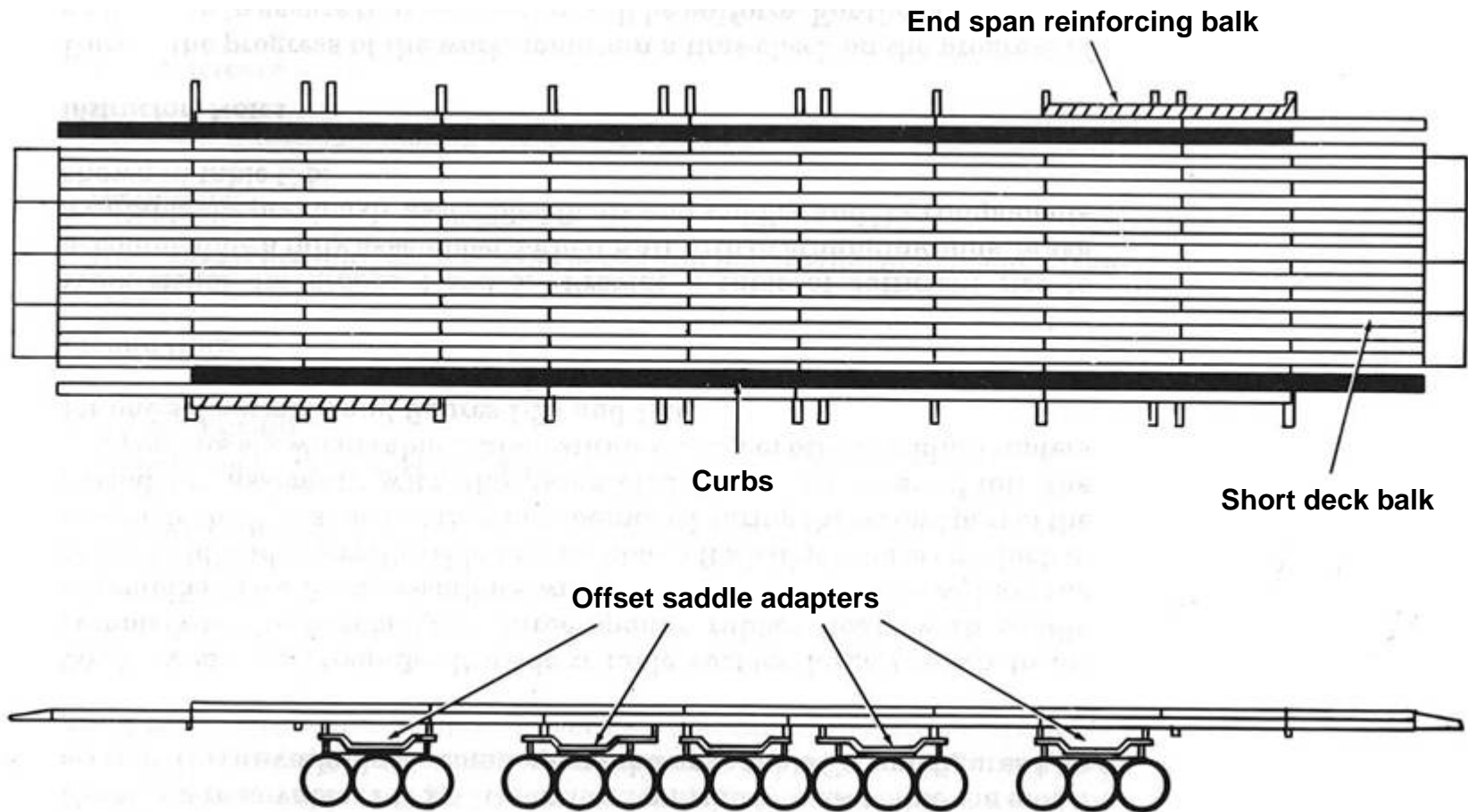

Figure C-11. 5-float reinforced raft with ramps

First Hour

Work stations for groups 1 and 2. Provide a table surface for each station large enough to accommodate one pneumatic float with saddle assembly. Provide a removable (1 ft x 4 ft) platform on which to assemble the model section. Have available the components shown in table C-1 and figures 1-2a and 1-2b.

Work station for group 3. Provide a table surface large enough to accommodate the assembly of three sponge rubber floats with saddle assemblies. Two float assemblies will use the normal and one will use the offset saddle adapters. Provide a removable (4 ft x 5 ft) platform on which to assemble the floats, so that they may be moved during the second part of the period for assembly with the assembled floats. Have available the components shown in table C-2 (substitute one set of offset saddle adapters for one set normal), and figures 1-2a and 1-2b.

Second Hour

Work station for groups 4 and 5. Provide a table of sufficient size to accommodate a fully assembled 5-Float Raft with overhanging ends. Make available the previously assembled floats and saddles and the components shown in table C-5.

Instructors Notes

During the progress of the work, maintain a time check on the progress of each group to assure that completion will be uniform. For the benefit of all students, describe and explain the problems that arise during the work of

any one group. When the final assembly of all components is completed, insure by summary and critique that all students are familiar with the nomenclature and assembly procedure for all parts of the raft.

Text Reference

TM 5-210 (Military Floating Bridge Equipment).

Disassembly

Have the students disassemble the model and replace the components in the chests.

Fourth Period

Assembly of Deck Balk, Fixed Spans

Classroom Procedure

First 1/2 Hour

Divide the students into two groups.

Group 1. To group 1 assign the work station containing the components (table C-4 and fig. 1-2c) required to assemble a trestle consisting of two columns and a transom. Have them assemble the trestle in the center of the gap over which the fixed span will be built.

Note: Inform students that in actual practice a single trestle assembly is

never used. Two trestle assemblies are a minimum requirement.

Group 2. Have group 2 observe group 1 assembling the trestle. After the trestle has been assembled, assign group 2 to the work station. It should now contain the assembled trestle and the components required (table C-6) for the assembly of the model of the 38-foot, 4-inch deck balk, fixed bridge. Group 2 then assembles the model of the 38-foot, 4-inch fixed bridge utilizing one trestle, as shown in figures C-12a and C-13.

Second 1/2 Hour

Reverse the procedure used in the first half hour of this period so that all students are familiar with the assembly of the 38-foot, 4-inch fixed bridge utilizing one trestle.

Classroom Setup

For the fourth period, the instructor provides a simulated gap to be bridged (approximately 36 inches wide) and a work station large enough (3 ft x 3 ft minimum) to assemble the model of the 38-foot, 4-inch fixed bridge utilizing one trestle. The required components (tables C-4 and C-6) are made available in two parts; one consists of components required for the trestle (table C-4), and the second consists of components required for the fixed bridge (table C-6).

Instructors Notes

During the progress of the work, maintain a time check on the progress of each group to assure that completion will be uniform. For the benefit of all
(Continued page C-32)

Table C-6. Components Required for Assembly of 38-Foot, 4-Inch Deck Balk, Single Span Fixed Bridge

Item	Number required
Adapter, curb	12
Balk, deck, normal	44
Balk, deck, short.....	22 *
Balk, deck, tapered	30
Pin, medium length	112
Plate, bearing	4
Posts, Handrail	3
Stiffener, balk	6

*The number of balk furnished in the model kit is not sufficient to build a complete deck for this type of fixed bridge.

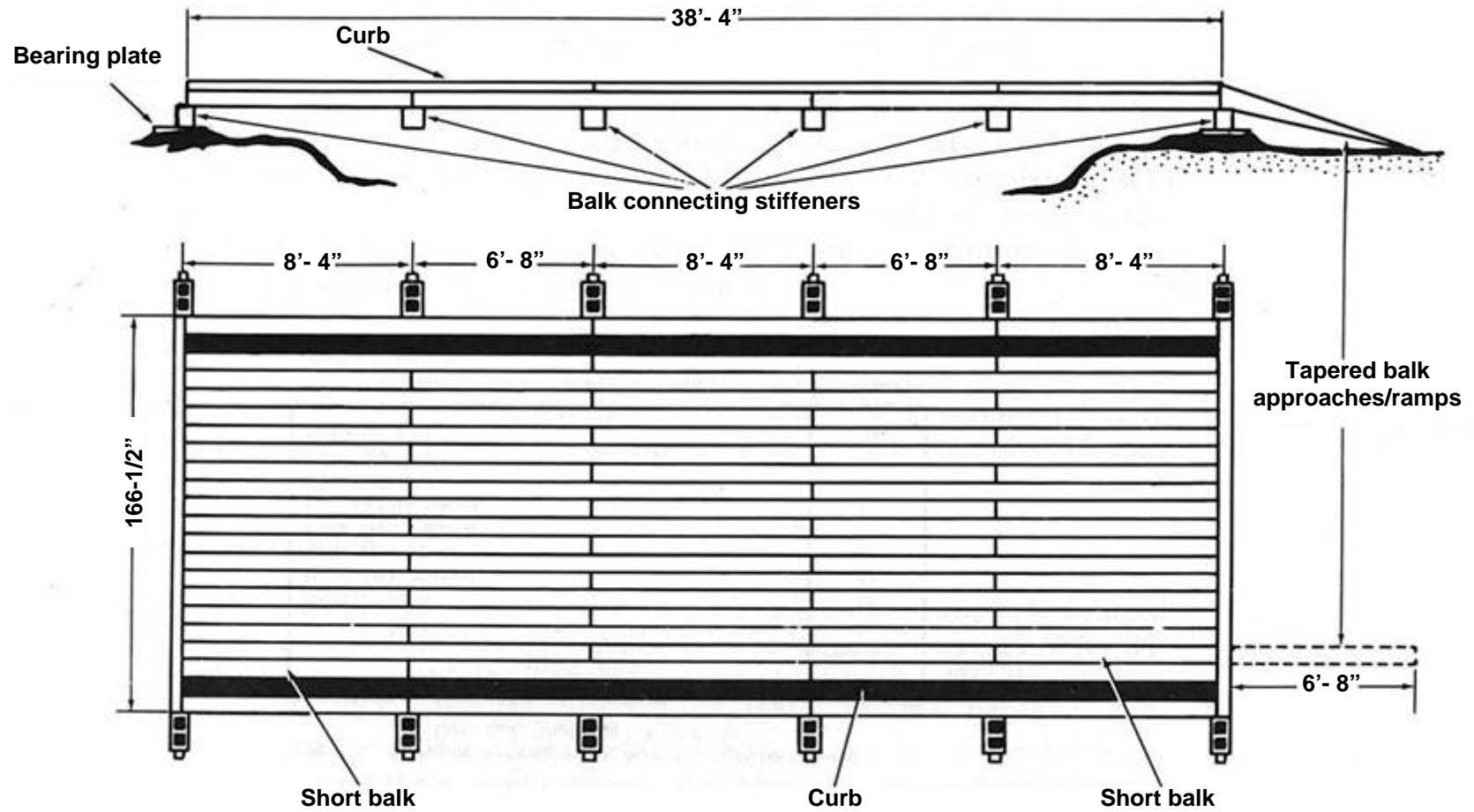

38'-4" Short span fixed bridge

Figure C-12a. Schematic diagram showing balk patterns and dimensions of deck balk single span fixed bridge

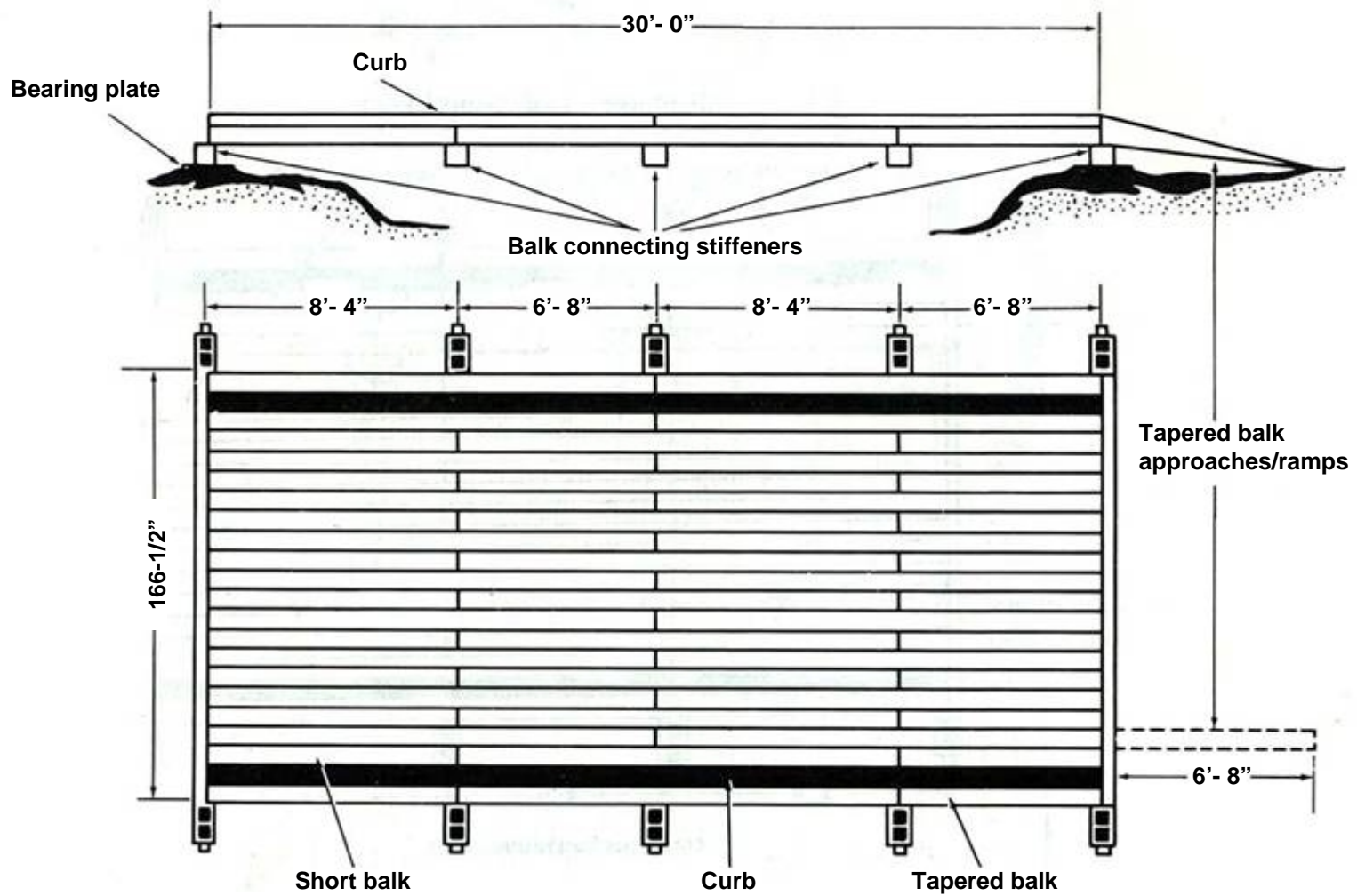

30 Foot short span fixed bridge

Figure C-12b. Schematic diagram showing balk patterns and dimensions of deck balk single span fixed bridge

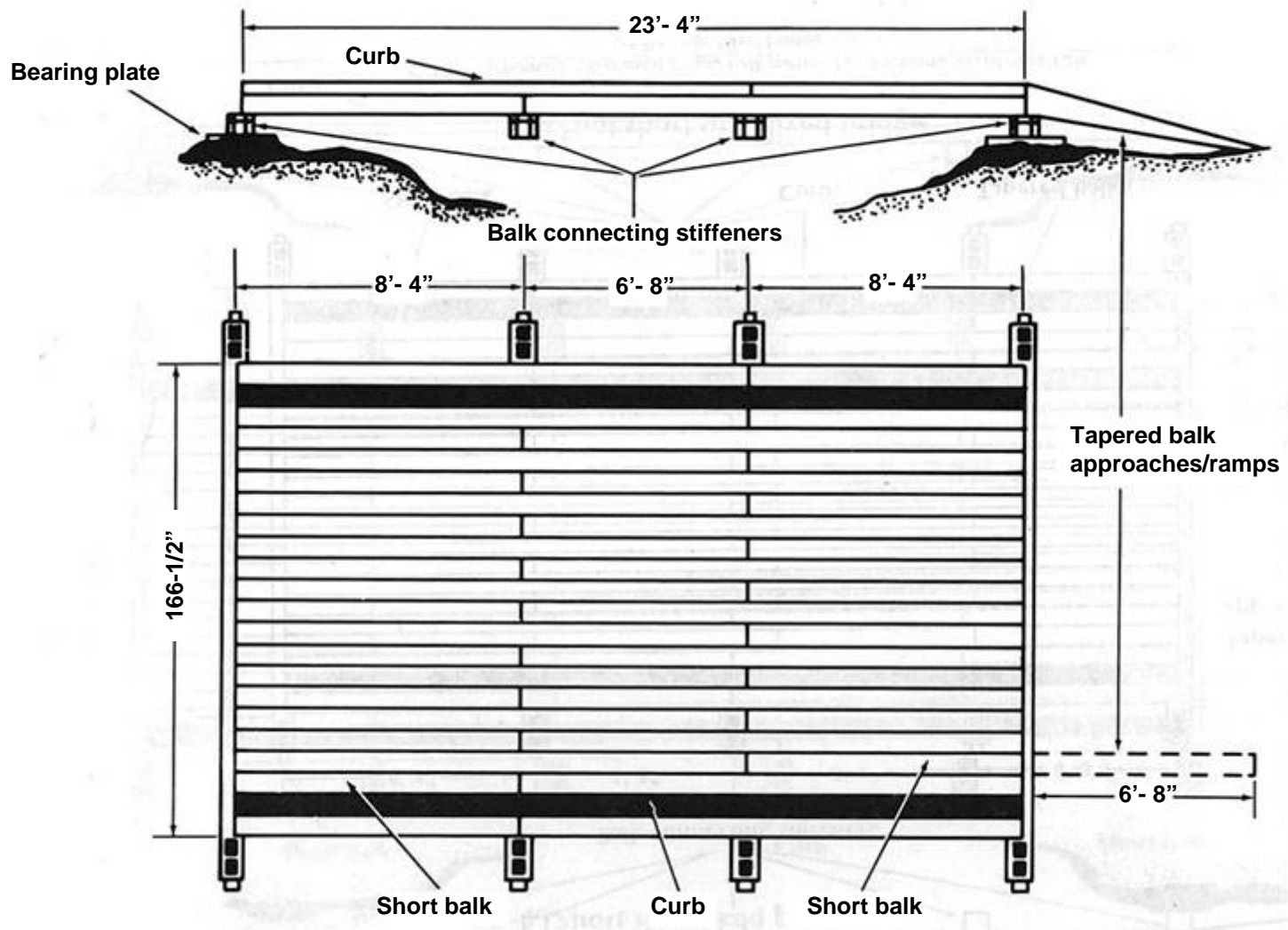

23'-4" Short span fixed bridge

Figure C-12c. Schematic diagram showing balk patterns and dimensions of deck balk single span fixed bridge

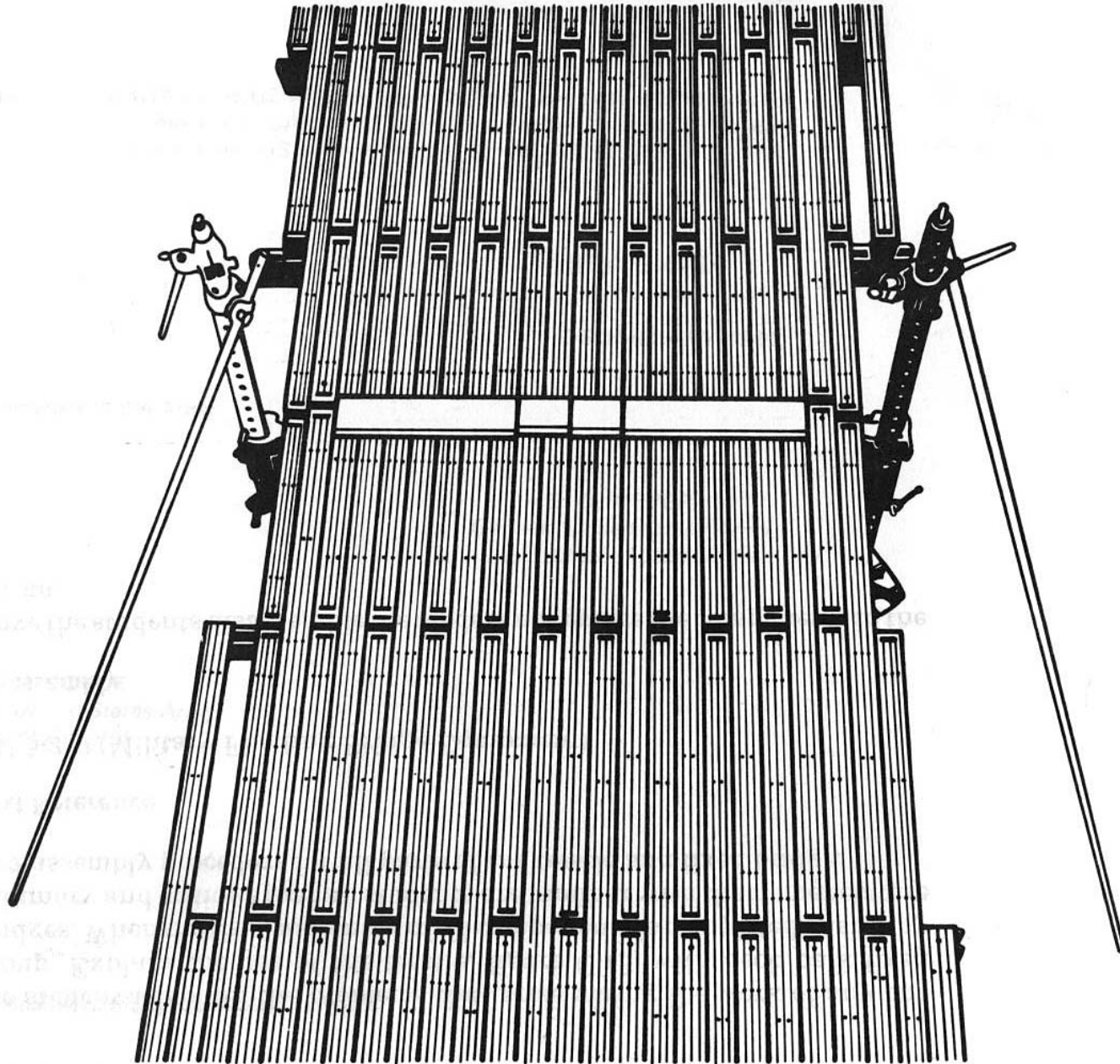

Figure C-13. Fixed span utilizing one trestle

the students, explain the problems that arise during the work of any one group. Explain the use of the trestle, figure C-13, with deck balk fixed bridges. When the final assembly of all components is completed, insure by summary and critique that all students are familiar with the nomenclature and assembly procedure for all parts of the trestle and fixed bridge.

Text Reference

TM 5-210 (Military Floating Bridge Equipment).

Disassembly

Have the students disassemble the model and replace the components in the chests.

The proponent agency of this GTA is the US Army Engineer School. Users are invited to send comments and suggested improvements on DA Form 2029 (Recommended Changes to Publications and Blank Forms) to Commandant, US Army Engineer School, ATTN: ATZA-TDL, Fort Belvoir, Virginia 22060.

GTA 05-04-034

25 JANUARY 1982

By Order of the Secretary of the Army:

E. C. MEYER
**General, United States Army
Chief of Staff**

Official:

ROBERT M. JOYCE
**Brigadier General, United States Army
The Adjutant General:**

DISTRIBUTION:

USA Training and Audiovisual Support Centers (TASC).

